

# THERMAL CLEANING OF METAL PARTS & TOOLS



Systems & Services for the Plastics, Fiber and Nonwovens Industries



Clean, safe & fast ■ German Art of Engineering since 1969

## SYSTEM VACUCLEAN

Gentle & green

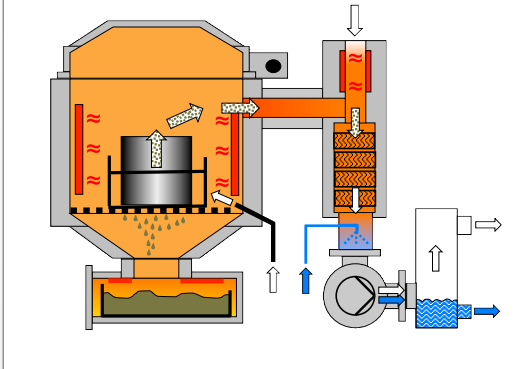

Cleaning time: 8-30 h



SCHWING

VACUCLEAN gently removes organic contamination from heat resistant metal parts by melt-off and thermal decomposition under vacuum.

### ADVANTAGES

- Especially gentle cleaning of temperature sensitive parts and tools
- Only electricity and water required
- Catalytic converter for off-gas cleaning

Especially recommended for:

- Spinnerets, melt-blown and spunbond dies
- Filter bundles, leaf disks
- Blown film die heads
- Extruder screws

## SYSTEM INNOVACLEAN

Fast & flexible

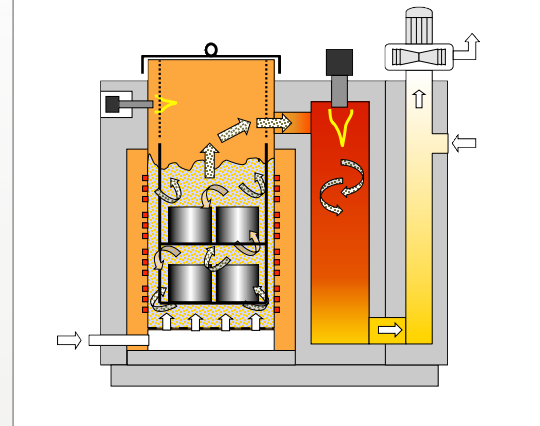

Cleaning time: 1-4 h



SCHWING

INNOVACLEAN removes all organic contamination (including halogenated polymers) from heat resistant metal parts by thermal decomposition in a fluidized bed.

### ADVANTAGES

- Very short cleaning times
- Suitable for all polymers (incl. PVC, PTFE, PEEK)
- Highest flexibility

Especially recommended for:

- Spinnerets, assembled spin packs
- Breaker plates
- Special profile dies
- Hot runners

## SYSTEM MAXICLEAN

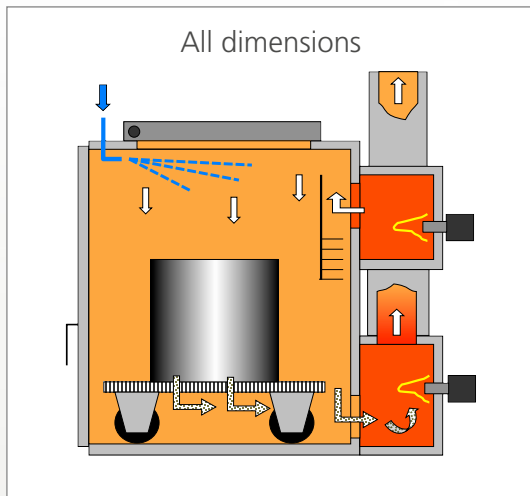

Cleaning time: 4-8 h



SCHWING

MAXICLEAN is a gas-heated thermal cleaning system. It removes organic contamination from large metal parts and tools by thermal oxidation.

### ADVANTAGES

- For large parts and machine tools
- Applicable for large amount of polymers
- Suitable for most polymers

Especially recommended for:

- Filter bundles
- Extruder screws
- Large extrusion and pelletizing dies
- Large hot runners

## SYSTEM COMPACTCLEAN

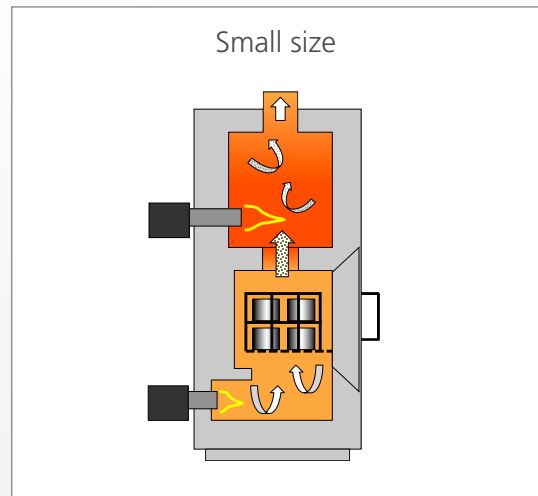

Cleaning time: 3-5 h



SCHWING

COMPACTCLEAN is a small gas heated thermal cleaning system, which removes organic contamination by thermal oxidation. It can be integrated easily into a workshop.

### ADVANTAGES

- Low investment
- Suitable for most polymers
- Small footprint

Especially recommended for:

- Non-return valves
- Breaker plates
- Small runners
- Needle valves, nozzles

# OUR EXPERTISE – YOUR BENEFITS

## TYPICAL COMPONENTS

- Injection moulding:
- Screws
  - Nozzles
  - Static mixers
  - Needle valves
  - Non-return valves
  - Hot runners
- Extrusion:
- Screws
  - Screw elements
  - Breaker plates
  - Screen changers
  - Filter, Filter plates
  - Profile dies
  - Blown film die heads
- Fiber / Nonwovens:
- Spin packs
  - Spinnerets
  - Spinning pumps
  - Spinning beams
  - Filter bundles, candles

## FOR ALL POLYMERS

- Polyolefins: PE, HDPE, PP, PB, EVA, EVOH
- Polyesters: PET, PBT, PC, PTT, PEN
- Polyamides: PA6, PA6.6, PA12, PPA
- Halogenated Polymers: PVC, PTFE, PVDF
- Polyacrylates: PAN, PBA, PMA, PMMA
- Polystyrenes: PS, ABS, SB, SBS, SAN
- Polysulfides: PPS, PSU, PES, PPSU
- Biopolymers: PLA, PEA, PVAL, PPOX
- Polyetherketones: PAE, PEK, PEEK
- Polyimides: PI, PBI, PEI, PBO, PMI
- Polyurethanes: PUR, TPA, TPO, TPU, Spandex
- Special Polymers: LCP, POM, BR, NBR
- Your specific polymer: ...

## PERFECTLY CLEAN

- Removal of all polymers
- Free of all polymer & carbon residues
- No damage to parts and tools

## FLEXIBLE SOLUTIONS

- All thermal cleaning methods
- Systems for assembled, disassembled and complex parts and tools
- All sizes and geometries of parts

## INTELLIGENT & SAFE

- Easy and safe operation
- Intelligent control systems
- Automated process management

## ENVIRONMENTALLY FRIENDLY

- Integrated or separate off-gas cleaning
- No polluted water
- Minimized energy consumption

## SERVICE & SUPPORT

- Process consulting and planning
- Commissioning and training
- Technical support

# ACCESSORIES

In addition to its Thermal Cleaning Systems, SCHWING offers optionally a variety of accessories and post treatment systems:



Chimney elements



Bubble test units



Loading baskets, tables and racks

Thermal afterburning systems



Ultrasonic & rinsing units

Quality inspection systems



High pressure washers



Shot blasting systems



# CLEANING SERVICES



Working from its manufacturing headquarters in Germany, SCHWING designs, engineers, manufactures and markets the most advanced Thermal Cleaning Systems since 1969. Valuable experience resulting in industrial leadership and excellent processes with perfect results for the plastics and fiber industry.

For more than 25 years, the SCHWING Group has provided high quality contract cleaning services around the world.

Each year more than 250,000 parts are cleaned for hundreds of customers. SCHWING's experience and know-how provides strong application support for its customers.

Depending on the specific requirements or applications, different Thermal Cleaning Systems are available to remove organic contamination.

The complete range of equipment can handle component weights of more than 5,000 kgs



(e.g. a blown film die head) and part lengths up to 6 meters (e.g. nonwoven dies and extruder screws).

In order to obtain completely clean parts, specialized post treatment methods have been devised especially for complex parts like spinnerets, spin packs, filter discs and candles.

The cleaning results are always verified and documented by precise process control, strict quality procedures and inspection techniques.

SCHWING has the vast expertise and total experience for all procedures in thermal cleaning and post treatment. Rely on SCHWING's professionalism for all of your sophisticated cleaning needs.

**German Art of Engineering  
since 1969**



SCHWING Technologies GmbH  
Oderstrasse 7  
47506 Neukirchen-Vluyn · Germany  
Phone: +49 (0) 2845 930-0  
E-mail: [info@schwing-tech.com](mailto:info@schwing-tech.com)  
[www.thermal-cleaning.com](http://www.thermal-cleaning.com)

Visit us on:   

